

The all-new Mercedes-Benz GLC Coupé.



Mercedes-Benz



More than an SUV. More than a coupé. More than ever before.

Some personalities immediately make their mark. With their appearance. Their self-assurance. And their unique character. Much like the new GLC Coupé, which combines the merits of an SUV and a coupé like no other. In a style all of its own. More dynamic and sportier than ever. With wider aprons, new tailpipe trims and, fitted as standard for the first time, MULTIBEAM LED with sophisticated light design. The host of new wheel designs take its unique sporty and elegant character to the highest level.



Effortless communication with MBUX.

As well as understanding what you say, the new GLC Coupé also responds instantly to your touches and gestures. This is thanks to MBUX, the sophisticated Mercedes-Benz User Experience, which boasts a wealth of new control and display features. Like the large media display with touch function or the fully digital instrument cluster with navigation display.

Say 'Hey' to the future with MBUX.

MBUX touch control concept

So absorbing that it's hard to leave alone. The sophisticated MBUX touch control concept lets you determine exactly what it shows you and how you control it. As intuitively as on a smartphone. Either with the new touchpad with haptic feedback, or by using the Touch Control buttons on the new steering wheel, or on the touchscreen. The choice is yours.

MBUX voice control

It's always best to talk. The MBUX (Mercedes-Benz User Experience) infotainment system with intuitive voice control is optionally available for the new GLC. It understands what you say and obeys your commands using natural speech recognition. It takes only two words: "Hey Mercedes." And the new GLC Coupé is all ears.

Media Display

The high-resolution media display with touch control plays your multimedia content in razor-sharp quality and with brilliant images. The design of the large display with its extensive glazing will also impress you. The display reacts directly to your touch inputs, as with your smartphone or tablet.

- 26 cm (10.25-inch) screen diagonal
- Resolution of 1920 x 720 pixels

Smartphone integration

Fully contactless operation of your smartphone is possible in the new GLC. Once it is connected via Bluetooth, NFC or USB cable, your numerous apps and functions appear on the media display, where you can control them conveniently using voice commands or touch controls.





Something special. On every trip, from any angle. With the Fit & Healthy features.

Not just a means of arrival at your destination, the new GLC Coupé is a thoughtful companion through your journey. The Fit & Healthy features understand, motivate and guide to keep you in the prime of your health while driving. Get ready to elevate your driving experience with a car that cares.

[Ambient lighting with 64 colours](#) | [Cruise Control](#) | [THERMATIC AC with 2 climate zones and integral fine particulate activated charcoal filter](#) | [Advanced sound system](#) | [Electrically adjustable seats with Memory function and Lumbar support](#)



Variants for the Made in India GLC Coupé.

GLC 300 4MATIC Coupé
GLC 300d 4MATIC Coupé

*Please read the disclaimer.

Petrol Engine – GLC 300 4MATIC

The ultra-modern petrol engine ensures spontaneous engine response and fast reaction to accelerator pedal movements. Efficiency measures include, intake CAMTRONIC, friction loss reduction package and improvements to NVH (noise, vibration, harshness).

The NVH improvements include insulation of the engine block and extensive covering of the engine with an acoustic insert as well as further optimisation in relation to the injection hydraulics. To guarantee excellent exhaust emissions, use is made of tried and-tested piezo injectors with good mixture preparation and a further-improved combustion chamber.

Diesel Engine – GLC 300d 4MATIC

These 4-cylinder diesel engines of the latest generation give a lot but take little. This is thanks to their particularly light, compact design and minimal frictional losses. Significantly less noise and vibrations bring the level of refinement virtually to that of petrol engines.



*Please read the disclaimer.

9G-TRONIC

When you select the Comfort and ECO drive programs via DYNAMIC SELECT, the 9G-TRONIC shifts through the nine gears for you smoothly and efficiently, thus providing optimum ride comfort. In addition, the transmission is also truly sporty: at the press of a button you can experience fast, sporty gear changes while nevertheless frequently driving in the optimum engine speed range. As such you can enjoy even more driving pleasure in Sport mode as a result of correspondingly better performance.

Performance remains excellent, while ride comfort is enhanced and noise levels are reduced. Smaller gear ratio increments and faster gear changes lead to even greater responsiveness and agility. At the same time, 9G-TRONIC impresses with smooth, barely perceptible gear shifting like that of a continuously variable transmission. As 9G-TRONIC is able to skip individual gears, multiple downshifts are possible for fast and powerful sprints.

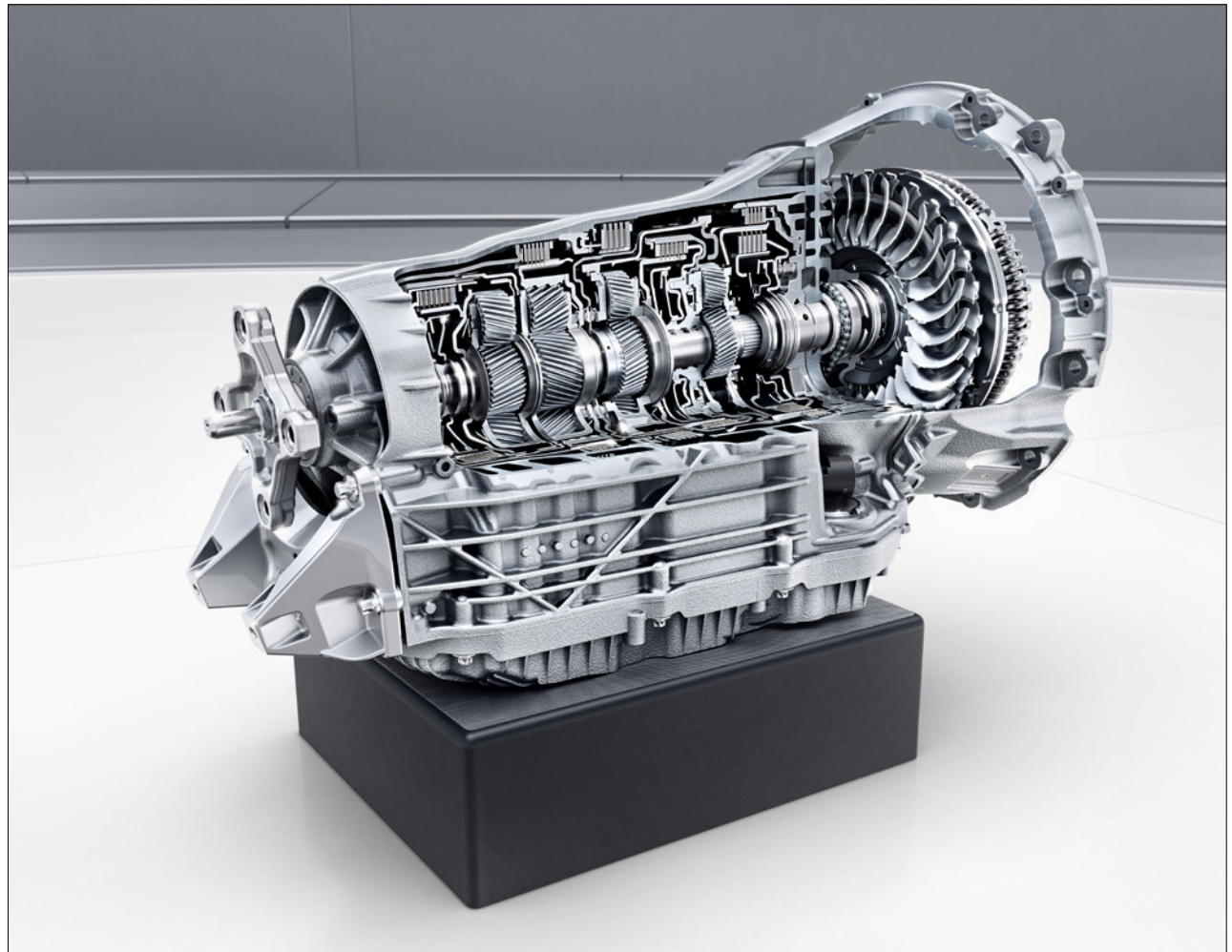

4MATIC

The 4MATIC all-wheel drive applies the power delivered by the top-performing engines to impressive effect. Always active, the system improves traction and handling in difficult road conditions in particular. It is reliable basis for sporty driving pleasure and a true safety advantage in the wet.



*Please read the disclaimer.

DYNAMIC SELECT

DYNAMIC SELECT changes the handling characteristics at the press of a button. Use different drive programs which change the characteristics of the engine, transmission, suspension and steering, for example. Whether dynamic in Sport and Sport+ mode, highly relaxed in Comfort mode or particularly economical in ECO mode – you determine precisely what is important to you.



*Please read the disclaimer.

MULTIBEAM LED headlamps

MULTIBEAM LED headlamps provide you with perfect light and visibility. For your perfect vision: the adaptive MULTIBEAM LED headlamps with individually controllable LEDs react to the traffic situation. Partial main beam omits other road users without dazzling them. ULTRA RANGE Highbeam increases the range to the permitted maximum. The cornering light and active light functions also illuminate the field of vision to optimum effect.



Mirror package

The Mirror package combines a number of useful functions for day-to-day driving: electrically folding exterior mirrors protect your vehicle from annoying damage when parking, the lowerable exterior mirror on the front passenger side makes parking easier and the self-dimming function protects your eyes.



*Please read the disclaimer.

Sliding sunroof

The electric glass sliding sunroof allows more light and air into your vehicle. Even when closed, and especially when open, it lends a brighter ambience to the interior. When the sliding roof is open, there is a pleasant flow of fresh air with no draughts. A movable roof liner gives additional protection from the sun.



Aluminium-look running boards with rubber studs

The aluminium-look running boards are a true eye-catching feature. They are mounted on the side at the height of the side skirts, thus making it easier to get into the front as well as the rear. Slip-resistant rubber studs ensure a firm foothold.



*Please read the disclaimer.

EXCLUSIVE interior

With the EXCLUSIVE interior there are three stylish colour concepts (black, silk beige and magma grey). Together with the fine open-pore black ash wood elements create an elegant contrast. They characterise the individualistic appearance of the interior and provide both a high level of comfort and outstanding support.

- The 31.2 cm (12.3-inch) fully digital instrument display delivers a pin-sharp image which is very easy to read in all light conditions. It also provides three display styles "Classic", "Progressive" and "Sporty" with MBUX
- Seats with exclusive upholstery layout in ARTICO man-made leather
- 3-spoke multifunction sports steering wheel and two-piece bezel on the front in silver chrome
- Instrument panel and door beltlines in ARTICO man-made leather
- Air vents with outer adapter tubes in Nürburg silver, vent surround, rotary knob and front face of the louvres in silver chrome
- Door centre panels in ARTICO
- Black fabric roof liner and beige fabric roof liner



All-digital instrument display

The fully digital instrument display with the display styles "Classic", "Progressive" and "Sporty" enables you to decide which information is important to you and in which way you wish to have it displayed. The 31.2 cm (12.3-inch) display delivers a pin-sharp image which is very easy to read in all light conditions.

Electrically adjustable front seat with memory function

Comfortable and individual adjustment of the seating position and head restraint is made possible by the electrically adjustable driver's seat – for pleasant journeys with a healthy posture. The included memory function is particularly useful if different drivers use your vehicle and the seat adjustments are changed frequently.



*Please read the disclaimer.

Parking Package with 360-degree camera

Optimum parking service on board. Active Parking Assist with 360° camera makes it easier for you to find a parking space and to manoeuvre into and out of parking spaces. The choice is yours: thanks to all-round visibility you can park your vehicle yourself – or have your vehicle parked stress-free.

Ambient lighting with 64 colours

Showcase the interior according to your personal preferences or current mood. With a total of 64 colours, the ambient lighting gives you almost unlimited scope for lighting schemes, and has the right colour available for any situation.



*Please read the disclaimer.

Wireless charging

No wires. No worries. Just a fully charged battery. You can now charge your compatible smartphone conveniently and wirelessly in the new GLC Coupé. Simply place it in the centre console's stowage area. The multimedia system recognizes your mobile phone automatically, and charging starts. The system recognizes all compatible devices, irrespective of model and brand.

Touchpad with haptic feedback

Using the touchpad, you can operate the display of the infotainment system as you would a smartphone. Shift or enlarge the content quite simply with single gestures. Each input is confirmed with haptic feedback. The touchpad recognises your handwriting should you wish to enter addresses or phone numbers. Furthermore, additional controls are positioned around the touch-sensitive surface. This way you have direct access to key functions at any time.



*Please read the disclaimer.

Wind screen wipers with rain sensors

The electronically controlled rain sensor thinks for you: The system automatically detects when the windscreen is wet and controls the windscreen wiper interval accordingly – provided this has been activated beforehand. As a result, as a driver you have one less task to worry about when it's raining and can enjoy clear visibility.



Cruise control

Enjoy relaxed, fuel-efficient motoring on longer journeys in particular. For this you can preselect your desired speed and your vehicle takes over control of the speed. In addition to the travelling speed, the limiter helps you to observe a maximum speed. This enhances road safety and prevents you from incurring expensive speeding tickets.



*Please read the disclaimer.

THERMATIC automatic climate control

Individual climate comfort in the front seats comes courtesy of the THERMATIC automatic climate control with 2 climate zones: the driver and front passenger can set the temperature separately for each side. This is maintained at a constant level thanks to automatic climate control and a sensitive sensor system – completely without any need for manual adjustment. The desired climate can be achieved quickly thanks to the convenient and intuitive temperature and ventilation control – and always remains at the selected level even during changing weather conditions and varying levels of sunlight. Especially for the driver, the constantly balanced interior climate has a positive effect on concentration and fitness.

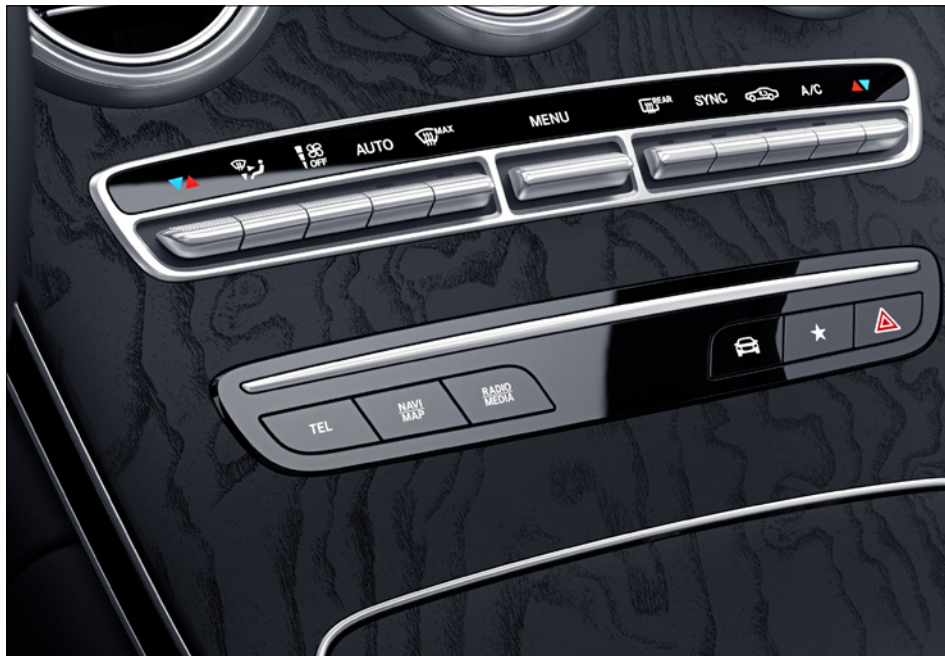

Advanced sound system

The sound system adds listening pleasure to driving enjoyment. The speaker system is precisely configured for the vehicle interior for the dynamic reproduction of music.

- 4 mid-range speakers
- 2 tweeters
- 2 Frontbass speakers
- 1 centre speaker
- 225 W amplifier output



*Please read the disclaimer.

Illuminated door sill panels with "Mercedes-Benz" lettering

Even getting in and out becomes an experience in itself. As part of this, the high-quality stainless steel sill panels are illuminated with striking "Mercedes-Benz" lettering. This shows that you value modern luxury.

2 USB ports in the rear

Using the two USB Type C ports in the rear, your passengers can charge mobile devices while on the move and therefore use them for longer. As such there is always sufficient battery charge available even on longer journeys, for example for watching films or browsing the internet on such devices.



*Please read the disclaimer.

Roller sunblinds in rear

The manual pull-out roller sunblinds protect against direct, bright sunlight in summer and when the sun is low in the sky. As a result your rear passengers are not dazzled and the interior heats up less. It still remains possible to see out of the rear windows – for a pleasant and eventful journey.

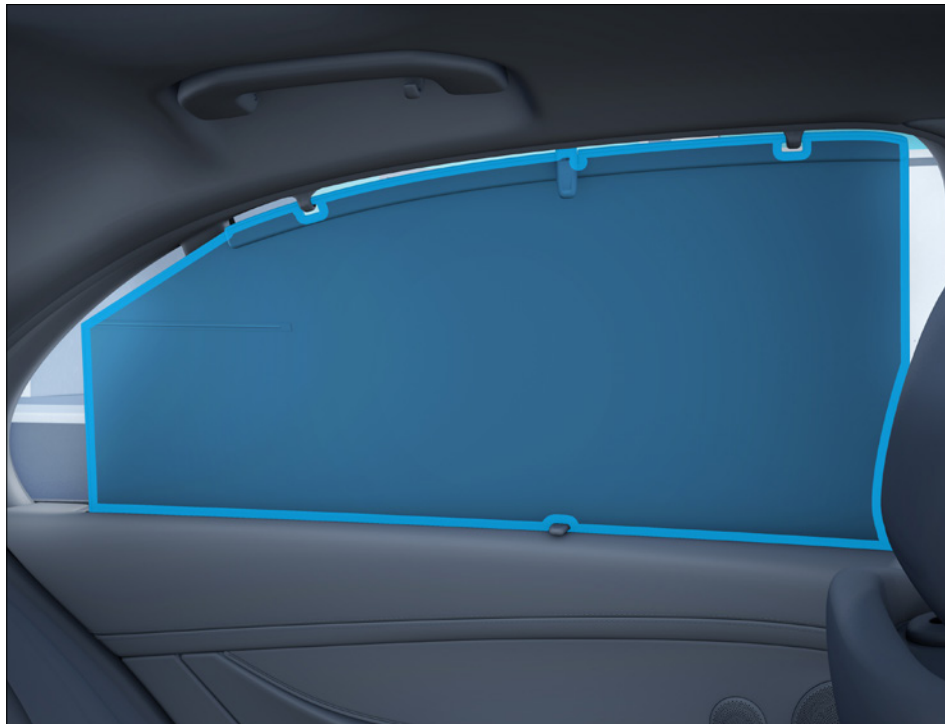

Hard disc navigation

Save time through fast hard disk navigation with flexible inputs via touch control or voice input. In this connection, the 3D displays of points of interest, for example, are also a visual delight. The intelligent system guides you reliably to your destination using both local and the most recent online data.



*Please read the disclaimer.

KEYLESS START

All of the drive authorisation functions are stored on your electronic vehicle key. Your engine starts as soon as you press the turbine-look start/stop button positioned in the ignition area while holding down the brake pedal. And it is just as easy for you to switch the engine off again. In hot weather you can quickly ventilate the vehicle thanks to the convenience opening and closing function – and in the rain also just as quickly ensure that the windows are fully closed. This is because you can control all of the windows via your vehicle key with just a press of a button: to open them simply hold down the unlock button, and to close them in turn hold down the lock button.



Velour floor mats

The velour floor mats additionally enhance your interior. They are finished in the respective appointments colour and edged. As such they blend into the interior design perfectly. In addition the mats protect the footwell against dirt – they can be removed easily to be vacuumed or cleaned.



*Please read the disclaimer.

Additional Interior Features

EASY-PACK tailgate

Protect your luggage from the sun and prying eyes: the EASY-PACK load compartment cover comprises of a retractable cover which is fitted behind the rear seats. You can remove this at any time and store it in the compartment provided beneath the load compartment floor.

EASY-PACK load compartment cover

Protect your luggage from the sun and prying eyes: the EASY-PACK load compartment cover comprises of a retractable cover which is fitted behind the rear seats. You can remove this at any time and store it in the compartment provided beneath the load compartment floor.

Emergency spare wheel

The narrow emergency wheel is lightweight and makes changing a tyre in the event of a breakdown simple. This enables you to reach the next service station even in the event of more significant tyre damage which it may not be possible to repair with TIREFIT tyre sealant.

Stowage space package with Collapsible crate

The Stowage Space package has numerous stowage and securing facilities for the interior and load compartment. Useful stowage spaces ensure that everything has its place. Small and large items of luggage can be optimally secured in place. It also includes Map pockets on the back of the front seats, Net on the load compartment floor, 12 V socket in load compartment on left, Cargo rail to expand the luggage compartment capacity by 30 l, Two USB-C ports in the rear.

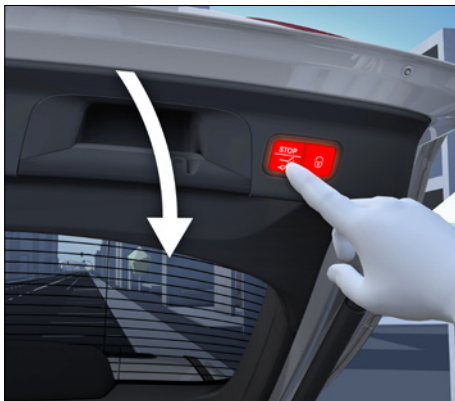

*Please read the disclaimer.

Mercedes me connect

Mercedes me connect allows drivers to stay in touch with their vehicles from anywhere in the world, and to obtain assistance at the touch of a button.

Vehicle Monitoring

Parked Vehicle Locator: It can locate your parked vehicle within a radius of 1.5 kilometres and show you on a map how to make your way back to the vehicle.

Vehicle Tracker: Your vehicle's geo-coordinates are sent by GPS.

Notification if the vehicle exceeds the set speed: Receive an alert if your vehicle exceeds a certain speed.

Vehicle Set-Up

Remote Retrieval of Vehicle Status: Information on Mercedes me App or the Mercedes me Portal.

Remote Door Locking and Unlocking: The Mercedes me App or from the Mercedes me Portal can lock the doors later if needs be.

Speed Alert: Receive an alert if your vehicle exceeds a certain speed.

Send2Car function: Send your address to your vehicle via an app.

Navigation Connectivity package

In combination with the standard-fit communication module (LTE) and the hard-disc navigation makes sure that you always reach your destination as quickly as possible by the best route.

Mercedes-Benz emergency call system

The Mercedes-Benz emergency call system can save you vital minutes in an emergency. If an accident is detected, a communications module with its own SIM card automatically triggers an emergency call which can shorten the time until the rescue services arrive.

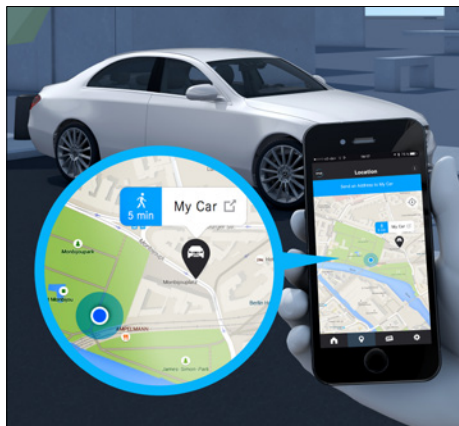

*Please read the disclaimer.

Safety and Assistance.

PRE-SAFE® system

With PRE-SAFE® the front seat belts can be electrically pretensioned in hazardous situations. As a result, the forward displacement of the occupants during braking or skidding can be reduced in an impending accident. In certain situations, the side windows or panoramic roof close automatically. In addition, the front passenger seat can be moved into a more favourable position in the event of a crash. In conclusion, the components of the PRE-SAFE® system can significantly reduce the risk of injury. For PRE-SAFE® Sound, a special sound chip generates a hissing noise through the speakers in the event of an imminent hazardous situation. In many cases the noise triggers a natural protective reflex: the tiny stapedius muscle in the ear briefly contracts and dampens the connection between the eardrum and inner ear. This way your hearing is better prepared for the loads resulting from noise generation in an accident.

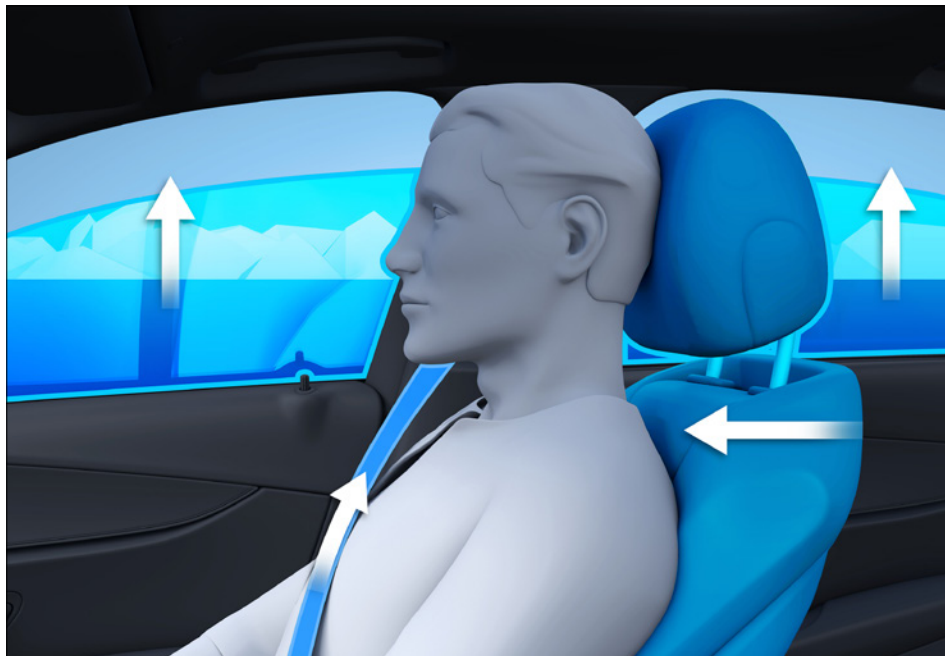

Active Parking Assist with PARKTRONIC

Turn the stress of tight parking spaces into effortless calm. Active Parking Assist with PARKTRONIC is not only able to find parking spaces – it also helps you to enter and leave them. As part of this it helps you with steering, and on vehicles with automatic transmission also with accelerating, braking and changing gear.

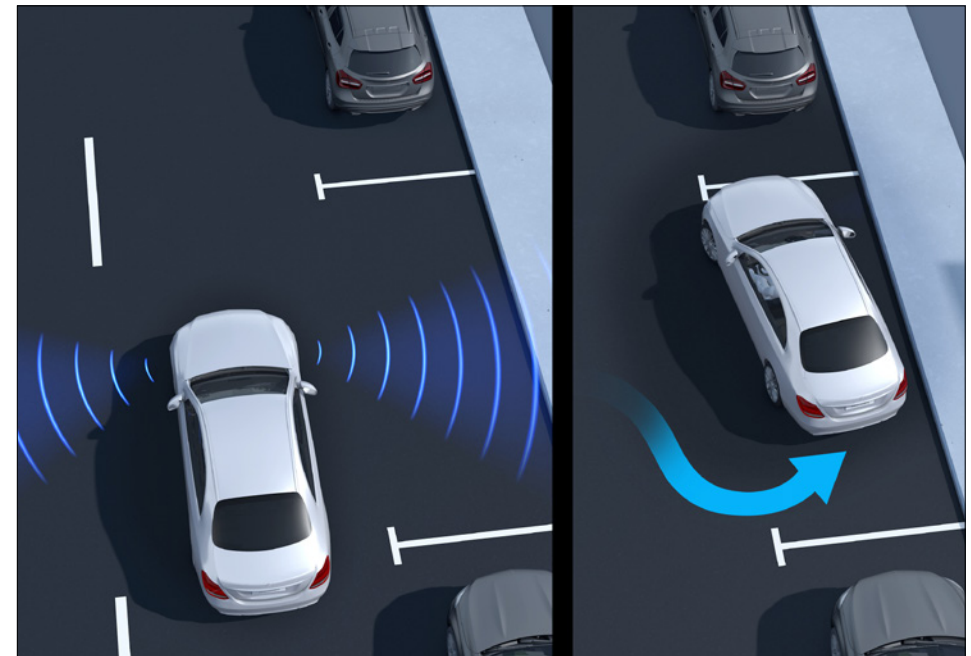

*Please read the disclaimer.

Safety and Assistance.

Kneebag

The kneebag protects your legs from contact with the steering column or the dashboard in a severe frontal crash. This can prevent or lessen the severity of injuries. The air cushion inflates in milliseconds and stabilises the whole body. This ensures that the entire restraint system including the seat belt work together optimally.



TIREFIT

Your rapid temporary measure in the event of less significant tyre damage. Damage caused by driving over nails or glass fragments can be sealed by means of the sealant blown in via the air compressor. As a result you can continue to drive to the nearest workshop at up to 80 km/h.



Tyre pressure monitoring system

The system monitors the tyre pressure for you and provides you with a warning in the event of a drop in pressure. This way you can react more quickly to these hazardous situations. Too low a tyre pressure can also result in longer stopping distances. When the control systems notifies you, you should top up the air quickly. Correct tyre pressure additionally increases mileage.

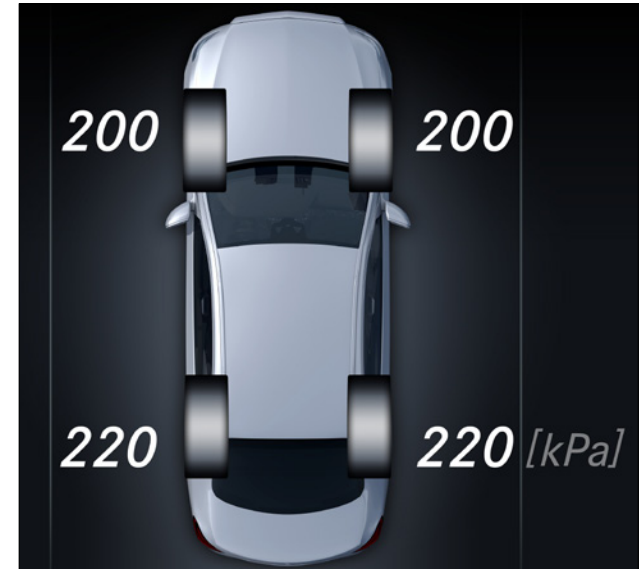

*Please read the disclaimer.

Upholstery, trim and alloy.

UPHOLSTERY

ARTICO man-made leather in silk beige/ espresso brown

ARTICO man-made leather in magma grey / black

ARTICO man-made leather in black



TRIM

Trim elements in open-pore black ash wood / light longitudinal-grain aluminium



ALLOY

48.3 cm (19-inch) 6-spoke light-alloy wheels painted in high-gloss black with a high-sheen finish



Paintwork.

Brilliant Blue

designo Hyacinth Red Metallic

Graphite Grey

Mojave Silver

Obsidian Black

Polar White



[Test Drive](#)[Contact Us](#)[Dealer Locator](#)

Technical data.

	GLC 300 4MATIC Coupé	GLC 300d 4MATIC Coupé
Total displacement / No./arrangement of cylinders	1991 cc / L4	1950 cc / L4
Rated output in kW (hp) @ rpm	190 [258]/5800-6100 kW [hp] at rpm	180 [245]/4200 kW [hp] at rpm
Rated torque (Nm @ rpm)	370/1800 - 4000 Nm at rpm	500/1600 - 2400 Nm at rpm
Transmission	9G-TRONIC	9G-TRONIC
Acceleration from 0 - 100 km / h (sec)	6.3 sec	6.6 sec
Top speed approx (km / h)	240 km/h	233 km/h
Maximum gross weight (Kg)	2435	2530
L x W x H (mm)	4658 x 1890 x 1644	4658 x 1890 x 1644

*Please read the disclaimer.

Dimensions.

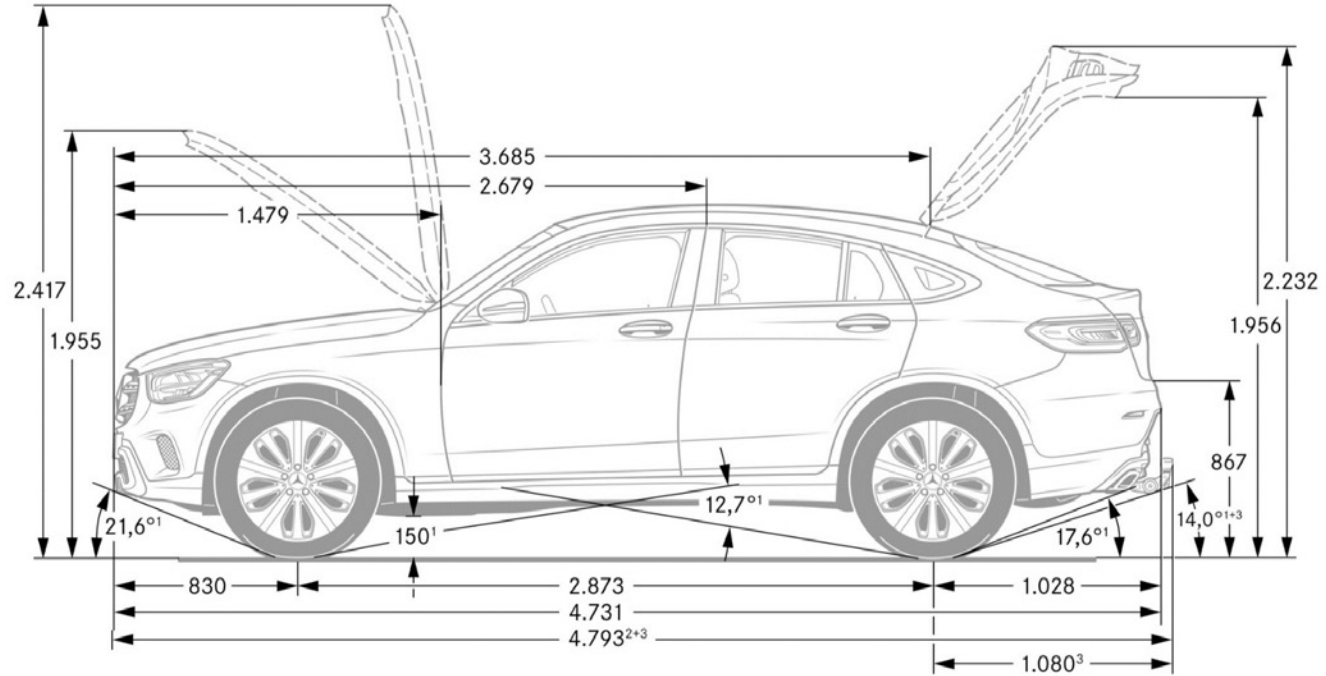
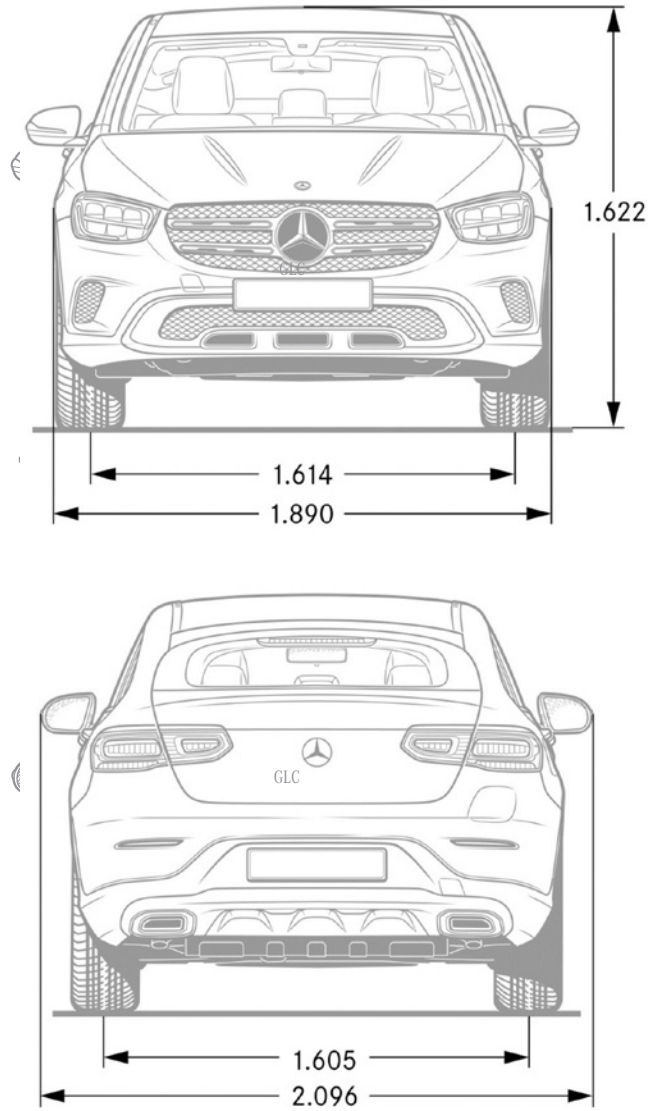

All dimensions in millimetres. The dimensions shown are mean values and apply to standard-specification, unladen vehicles.

*Please read the disclaimer.

My Mercedes. My Service.

You enjoy life. We'll take care of your Mercedes.

The best or nothing! This statement conveys how Mercedes-Benz aspires to develop and build highly desirable, top-class vehicles. The same passion, pledge and commitment apply to the Mercedes-Benz Service too. The bouquet of world-class After-Sales products will not only attend to every need of your Star but will also redefine the concept of ownership experience with a focus on providing end-to-end customer delight. After all, you Star deserves nothing less than the best.

STAR EASE

Delivering the best-in-class value

Servicing your Star does not get any better than this. With the STAR Ease Maintenance Packages, pay a defined cost of maintenance based on the model, contract period and mileage and say goodbye to spending on service every time. Plus, enjoy exclusive features like priority handling, shorter waiting time and quicker processes.



Advance Assurance Program

Extending your warranty coverage

With Advance Assurance Program, experience complete peace of mind. While this Extended Warranty Program kicks in the moment your standard 3 years warranty comes to an end, it can be extended further up to 6 years at a nominal price. Also, it comes with a bouquet of privileges for a worry-free time with your Star.



MOBILO

Providing you 24x7 mobility support

Your vehicle comes with Mobilo which provides round-the-clock on-road assistance service. Mobilo comes as a standard for 3 years and can be extended further up to 8 years at a nominal cost. This service offers privileges like vehicle towing facility, replacement vehicle, hotel accommodation, just to name a few.



*Please read the disclaimer.

My Mercedes. My Service.

Digital Service Drive

Ensuring convenience and transparency of service.

Servicing your Star is the last thing you will ever have to worry about. We provide transparent, convenient and hassle-free service. Our customer-friendly service features work around your busy schedule so that you have one less thing to focus upon.

Now booking your appointment is quick and easy.

To book your online service appointment, visit <http://mb4.me/SelectDealer>

Premier Express*

Because we value your time as much as you do.

Life gets busy and so we have designed Premier Express, our vehicle care service to help you get in and out quickly. While the visit will be brief, the service offered by our technicians will be comprehensive and complete. All to ensure your Mercedes-Benz is running for miles to come.

*Available at select locations only



*Please read the disclaimer.

My Mercedes. My Service.

Mercedes-Benz Genuine Parts Now with 2 years* of warranty

Mercedes-Benz Genuine Parts are crafted to the state-of-the-art standards of Mercedes-Benz, protecting your vehicle's performance while maintaining the style, comfort and safety, for the years to come. Also, they come with a warranty of up to 2 years, ensuring you a peaceful ownership experience with your Star.

* Terms & Conditions Apply



*Please read the disclaimer.

Mercedes-Benz Approved Tyres and Rims Ensuring every ride is a safe and joyful one

Maximise the safety and comfort of your Star with Mercedes-Benz approved tyres and rims. While the Mercedes-Benz approved tyres are designed to optimally match your car's performance, the Mercedes-Benz approved rims are designed to lend an exceptional style to the exterior of your Star and are also engineered for optimal performance.



Mercedes-Benz Genuine Chemical Products Because your Star deserves nothing but the original

Mercedes-Benz Genuine Chemical Products are specially tested for compatibility with the materials in our cars and meet the high quality standards. Also, our products have been approved under Daimler AG's strict, self-imposed environmental norms. Now with Mercedes-Benz Genuine Chemical Products, experience a whole new world of superior products that support throughout the car's life cycle.





INDIA'S LARGEST LUXURY CAR NETWORK

- ▶ Represented in 48 cities with 97 outlets
- ▶ 33 Integrated 3S dealerships
- ▶ 6 AMG Performance centers
- ▶ 20 Mercedes-Benz certified shop-in-shop outlets

Mercedes-Benz India Private Limited: E-3, MIDC Chakan - Phase III, Chakan Industrial Area, Kuruli & Nighoje, Tal: Khed, Pune - 410 501 (India)
Toll free No.: 0008000501888. e-mail: cs.ind@cac.mercedes-benz.com, **website: www.mercedes-benz.co.in**

Please note: This brochure is intended for general information, description and illustration of the Product including optional functions and equipment and may not be specific to a Product since specification of a product may change from time to time. Optional features, functions and equipment etc. may not be present in the Standard or Variant Product or Special Edition Product. Further, Standard specifications of a product may also vary from time to time. Colours may differ from those shown in pictures in the brochure, owing to printing. Mercedes-Benz India reserves the right to make changes, at any point of time, without prior notice, in design, colours, materials, components, equipment, specifications, features, functions, make and models etc. The information given in this brochure shall be regarded as accurate at the time of going to print and may vary thereafter due to any developments or any other reason. Interested parties should confirm with the Authorised Dealer about the correct specification of the product they desire to purchase. For the latest authentic information and updates, kindly contact your nearest Authorised Dealer.

All title, ownership rights and intellectual property rights in and relating to this brochure / magazine or publication material or any copies thereof including but not limited to copyright, logos, names, trademarks, service marks, design, text, images, links, concepts and themes are owned by Daimler AG and/or its subsidiaries collectively or used under authorised license by the Daimler AG. Any reproduction, transmission, publication, performance, broadcast, alteration, license, creation of derivative works or other use in whole or in part in any manner without the prior written consent of the Daimler AG is strictly prohibited.

Mercedes-Benz cars: The GLC Coupé meets Bharat Stage VI equivalent emission norms.

CIN - U34102PN1994PTC083160