



REVOLT



**GET READY
TO RIDE**

RV400

Explore your way

KNOW YOUR REVOLT

Description of components and parts	4
Description of speedometer	6
Remote control	7
Handle bar operations	8
Seat and Battery lock	11
MCB - Modular Circuit Breaker	12
Ready to ride – Power on	13
Battery use instruction	14

MYREVOLT MOBILE APPLICATION

User on-board	19
Home screen	20
Bike Location	22
Sound Screen	24
GeoFence	26
Switch Battery	29
Order Battery	31
Bike Diganostics	32

BATTERY AND CHARGING

Do's & don'ts for battery and chargers	34
Driving steps from start to stop	36

WARRANTY POLICY

Warranty policy on vehicle	39
Warranty policy on battery	41

BATTERY CARE & PRECAUTIONS

42



*Know Your
Revolt*

Description of Components and Parts

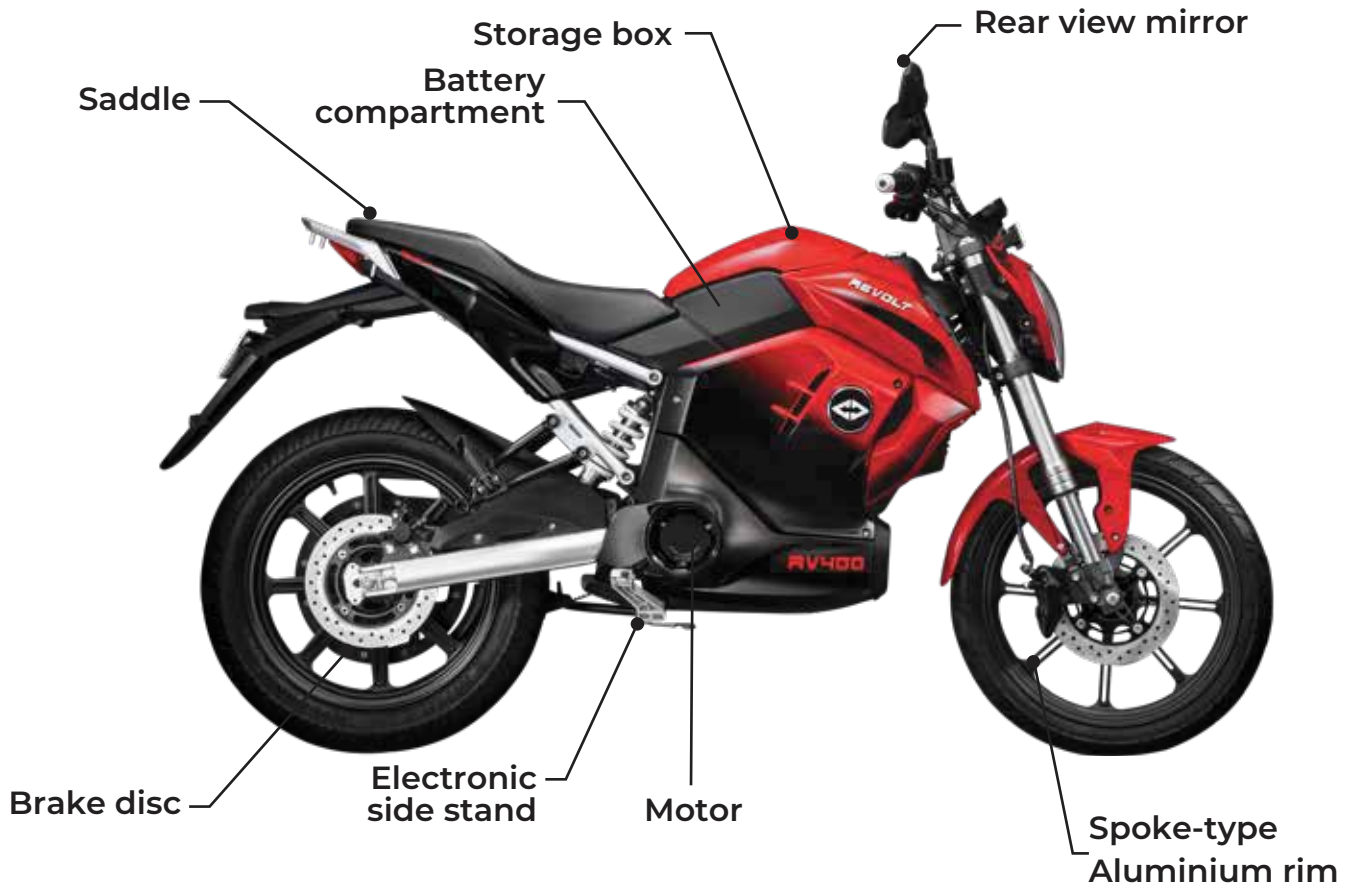

Description of Components and Parts

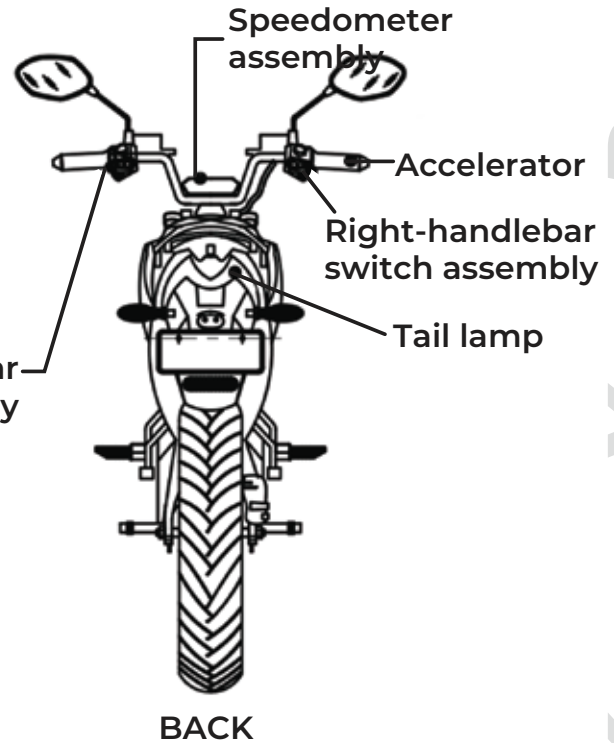
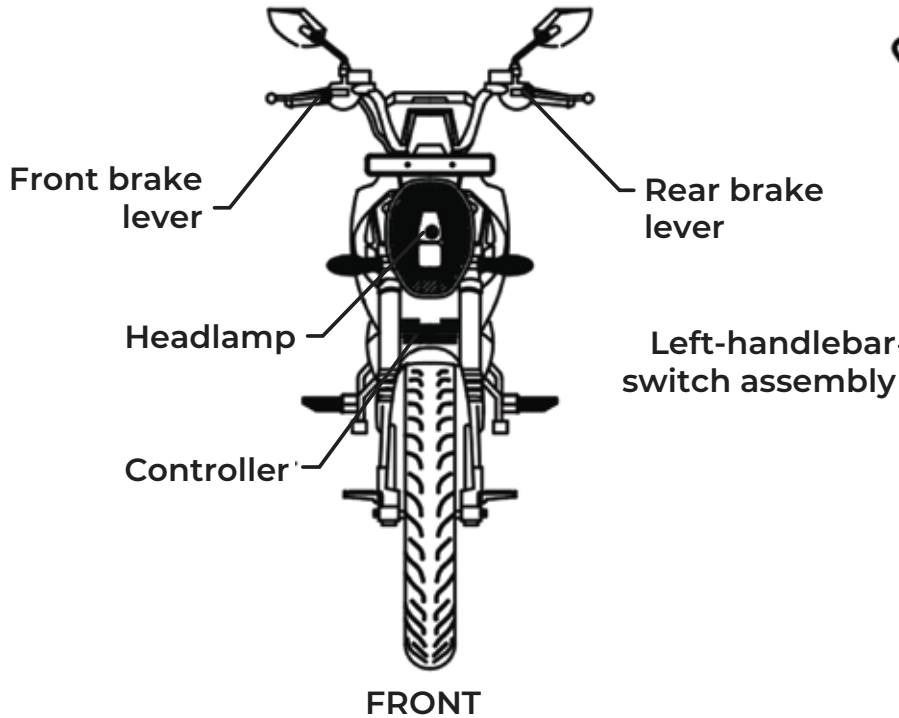

Description of Speedometer

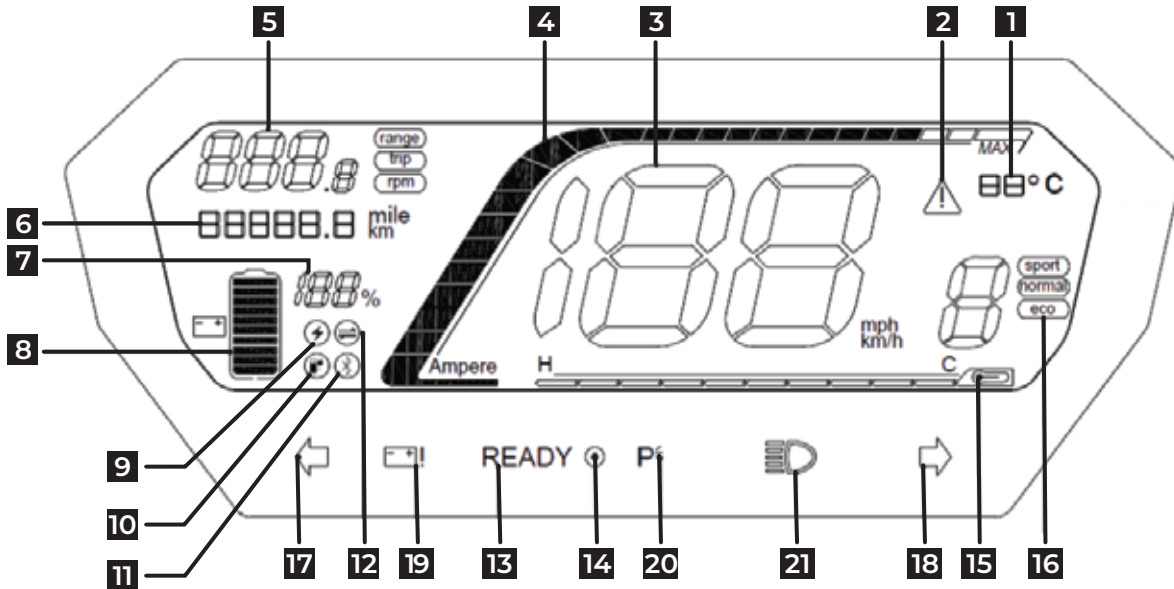

- 1 Ambient Temperature
- 2 Fault Code
- 3 Speed Display
- 4 Real Time Current
- 5 Mileage/ Trip/ RPM
- 6 Total Mileage
- 7 Battery Percentage

- 8 Battery Status
- 9 Short Circuit
- 10 Charging
- 11 Bluetooth
- 12 Data Connection
- 13 Ready
- 14 Ambient Light Sensor

- 15 Temperature
- 16 Mode Display
- 17 Left Indicator
- 18 Right Indicator
- 19 Battery Fault
- 20 Parking Signal
- 21 High Beam



Handlebar Switch Gear - Left

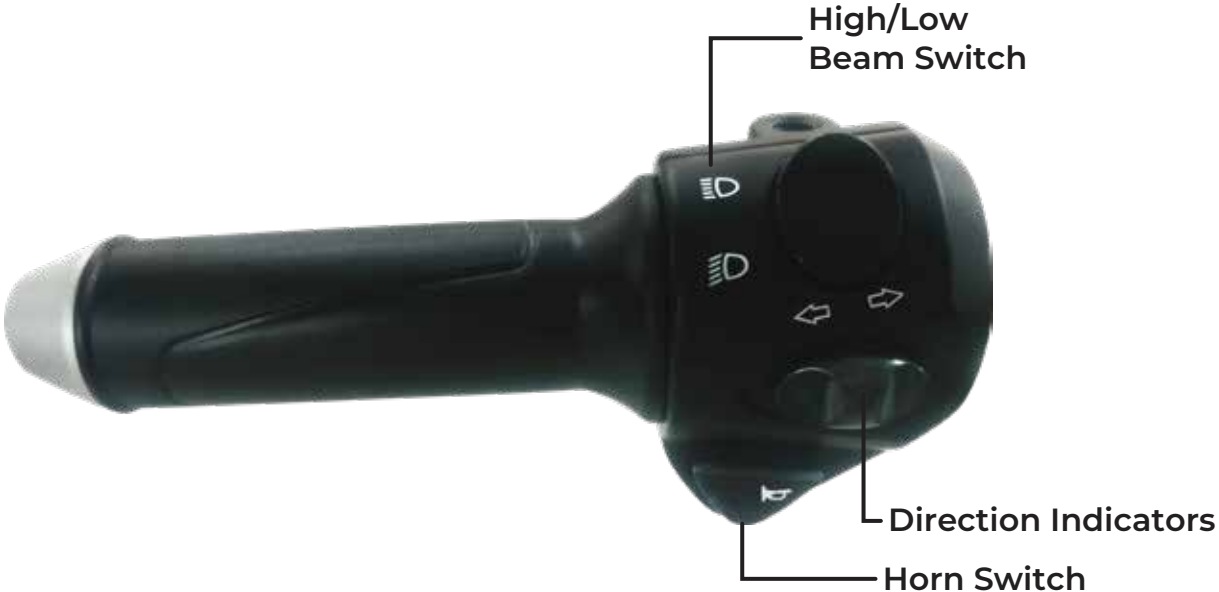

Know Your Revolt

Handlebar Switch Gear - Right

Parking Switch

Mode Switch

Sound on/off
Switch



Handlebar Lock / Unlock

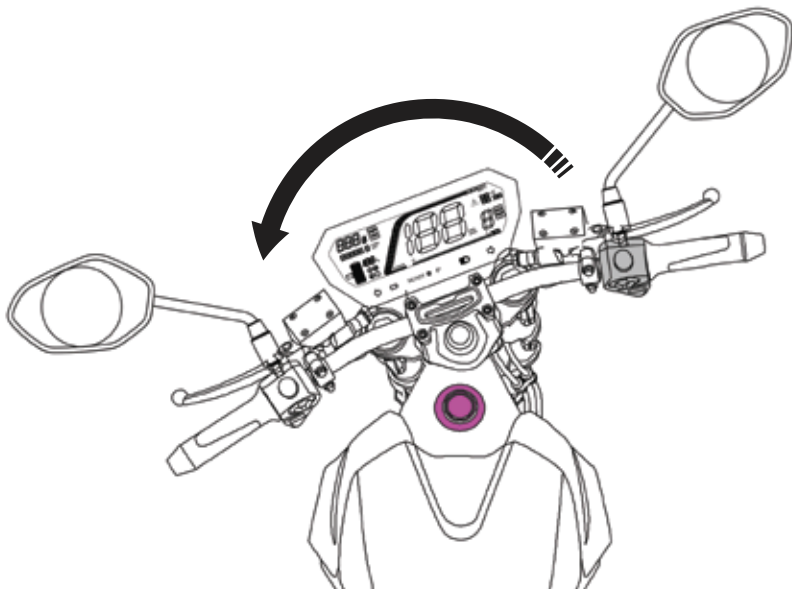

Put your motorcycle in parking mode using the parking switch and turn the handlebar to extreme left side

LOCK

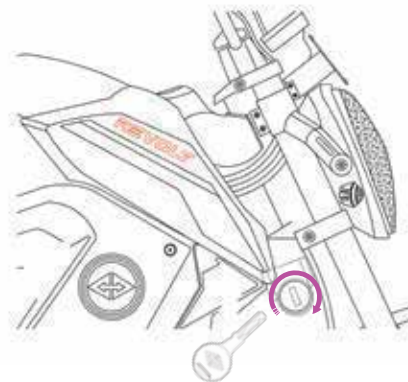

Insert the key in handlebar lock and turn the key clockwise

UNLOCK

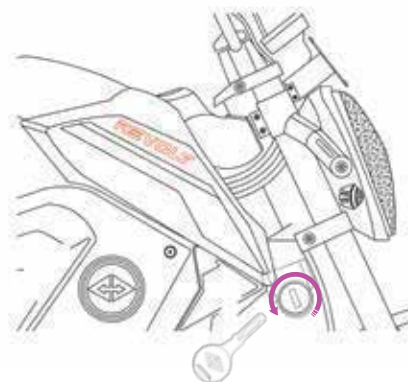

Insert the key in handlebar lock and turn the key anticlockwise



OPEN BATTERY COVER



Insert the key in storage seat lock, turn it clockwise until you hear a 'click' sound

OPEN SEAT

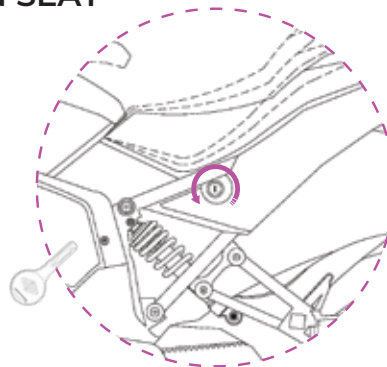

Insert key in storage seat lock, turn it anticlockwise affirmative sound.

MCB - Modular Circuit Breaker

In case the current goes over the set range due to an abnormal situation or short circuit, the MCB will trip automatically to disconnect the current flow between the battery and the motorcycle's wiring system.

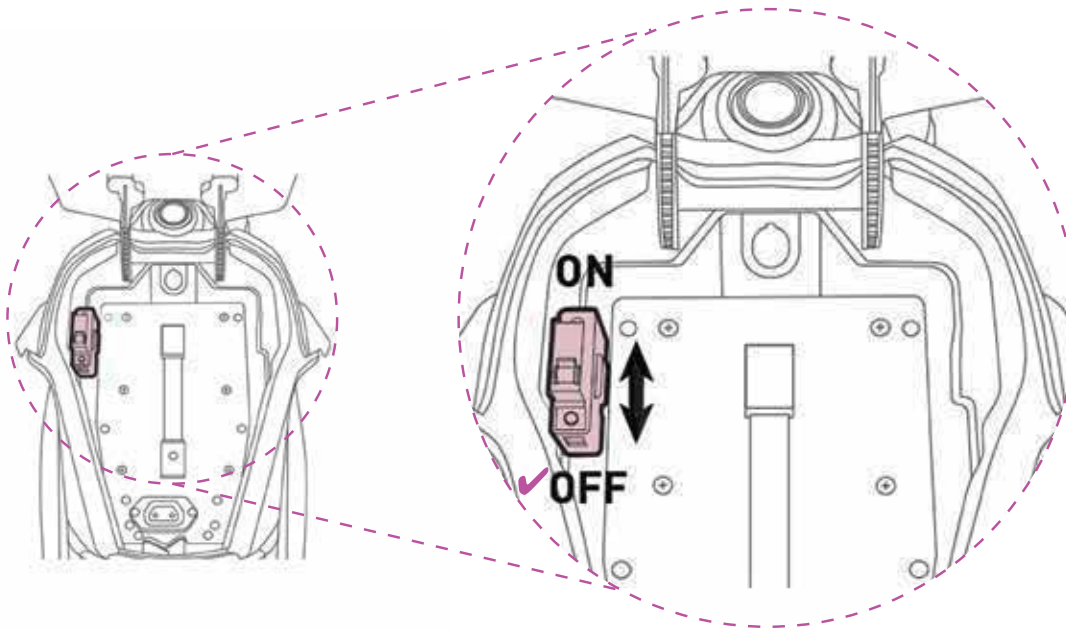

TIPS: For your own safety, put MCB at 'OFF' position:

- A. Before taking out the battery pack.
- B. Before cleaning and washing.
- C. Long time storage.



Press 'UNLOCK' on remote Smart Key

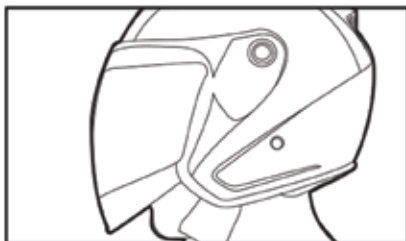

Put on your helmet

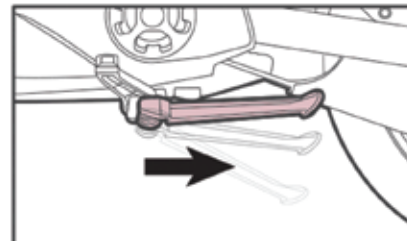

Get on the motorcycle, remove the side stand

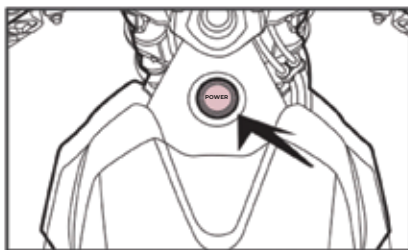

Press 'Power' button

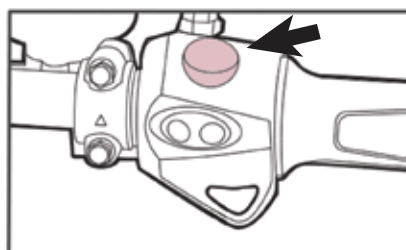

Toggle the parking switch to switch from parking mode to ready mode

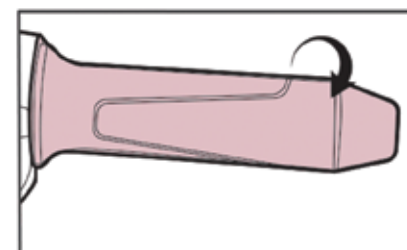

Turn accelerator gently to ride

Battery On-Boarding Charging

1. Connect the charger to the motorcycle charging port.
2. Connect the charger with power supply, during normal charging the red light will glow.

Note : Ensure that the charger is kept safe from any debris or water infusions.

CHARGING INDICATORS

Charging: Red light will glow.

Full Charged: Green light will glow.

Error: Red and green lights will blink alternatively.



EXTERNAL CHARGING

1. Open the storage, take out the storage cover, switch off the safety switch (MCB). The safety switch is mounted on the battery storage box.
2. Disconnect the battery power plug.
3. Insert the key in battery lock, turn it clockwise, then take out the battery pack from the motorcycle.
4. Connect charger with battery, then connect charger with power supply. The red light will glow indicating that the charger is working.

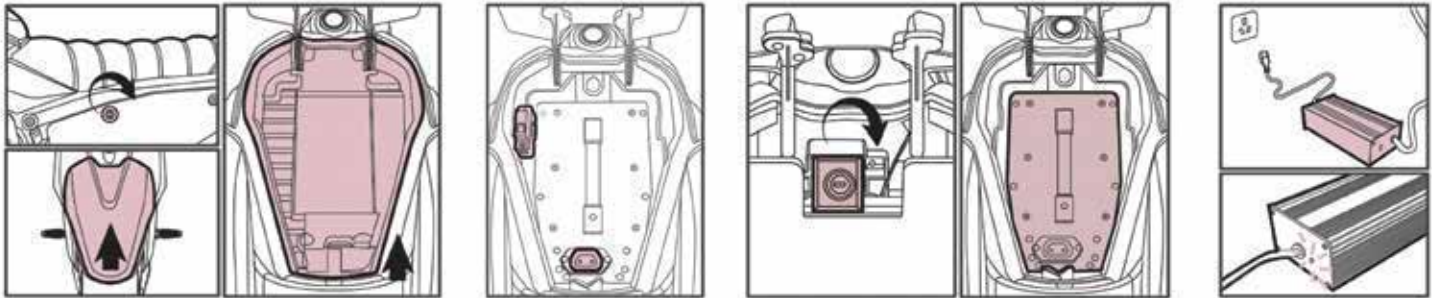

TIPS:

- Keep the battery pack away from water
- You must take out the battery pack from the motorcycle, and should be kept safely in room temperature if don't intent to use it for a long time.
- Children should not be allowed to touch the battery pack.
- Battery pack should not be put into fire.
- Always use genuine Revolt recommended charger, use of any other charger may damage the battery pack.
- All battery packs are checked for quality before delivery, under no circumstances the battery pack should be opened.

STORAGE, MAINTENANCE, TRANSPORT

1. In case the battery is not being used for a long time, please charge it until 50% (in case the battery is empty, charge it for 4.5 hours). Disconnect the battery from the motorcycle when storing them. Store in a dry ventilated place, at least charge it for 4 hours every month.
2. Battery pack and charger need to be stored in a clean, dry ventilated place, avoid contact with corrosive material, keep it away from power, fire and heat.
3. Battery storage condition: temperature -20 to 45 °C, humidity 65+-20%RH.

Using MyRevolt App



MyRevolt app will help you to connect with your motorcycle and obtain near real time information about your motorcycle. The built-in Artificial Intelligence in the app will show the battery charge information and allows you to swap the battery and get it delivered to your location. It also provides a way to secure your motorcycle through the use of its geofencing feature.

USER ONBOARDING

User onboarding will be done using mobile OTP based login. Please ensure that you have provided the same mobile number that was provided during motorcycle registration at your dealer.



PHONE NUMBER VERIFICATION PROCESS



This is the Home Screen of our App. The User will come on this screen everytime on opening the App or after successful login.

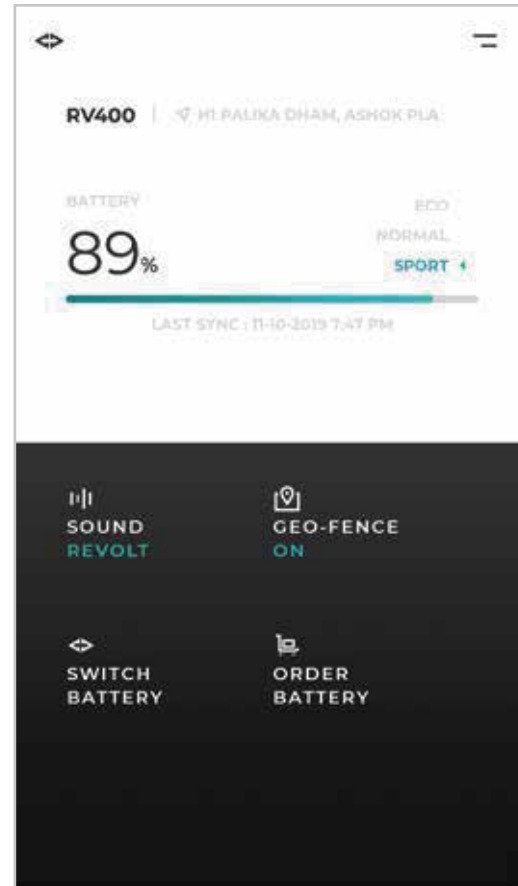

Battery Percentage

Current battery percentage of the bike. The color will change to indicate low battery warning.

Last Synced Time

Displays the time when motorcycle data was last synced with App.

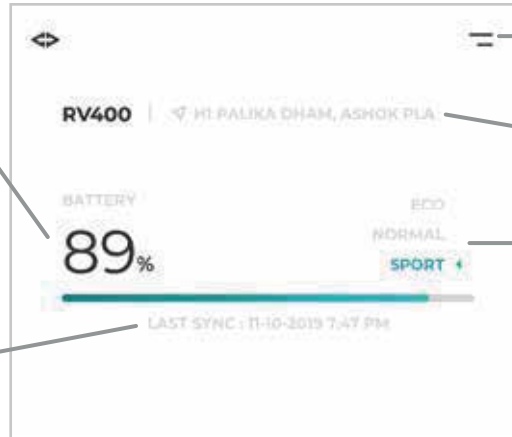

Opens up the navigation drawer

Motorcycle Location

Current motorcycle riding mode

Bike Location

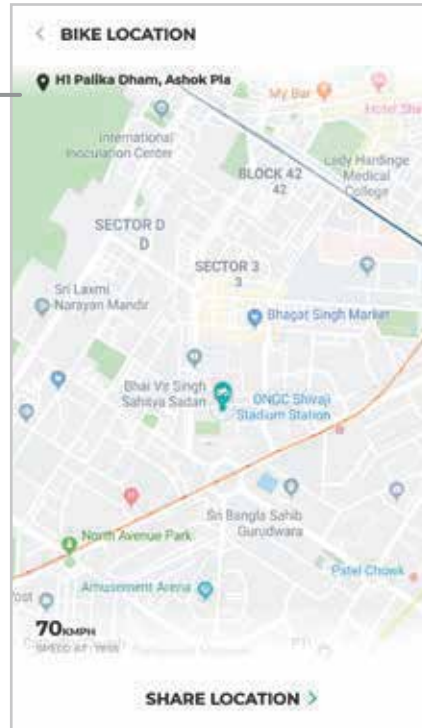

Clicking on the bike location on the home screen takes you to the bike location map.

This screen displays the motorcycle's location and speed. It also allows a user to share the motorcycle's location.

User can connect and change the motorcycle's sound. In case user is not able to connect, restart the bike and try again.

Users can find nearby Switch Stations to avail a battery Switch.



User can setup a geo-fence once the GPS location is displayed.

This is to enable users avail an emergency battery delivery.



Users need to click on the RVLT_MotoTone device for connecting to soundbox in iPhones.



Tap on these circular buttons to change the sound. This will change your sound on your motorcycle after your confirmation and this button will be highlighted to reflect the current sound of the bike.

You can tap on these cards to play a preview of that particular sound on your mobile device.

You can also change the volume of the soundbox by dragging this slider.

Note: User should ensure that the connecting mobile phone supports BLE 4.2

GeoFence -Used for protecting your bike

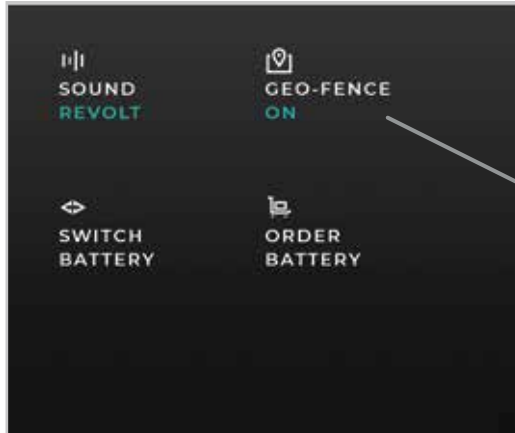

Clicking on this will allow the user to setup a new **Geofence**.

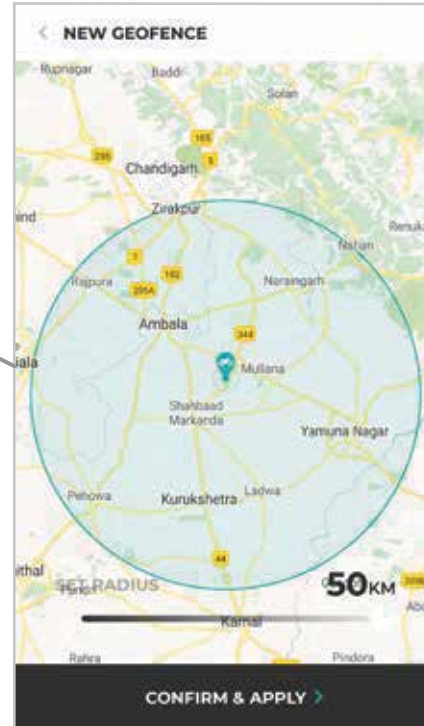

This is the geofenceradius

User can change the radius of the geofence

Clicking on **CONFIRM & APPLY** will setup the geofence

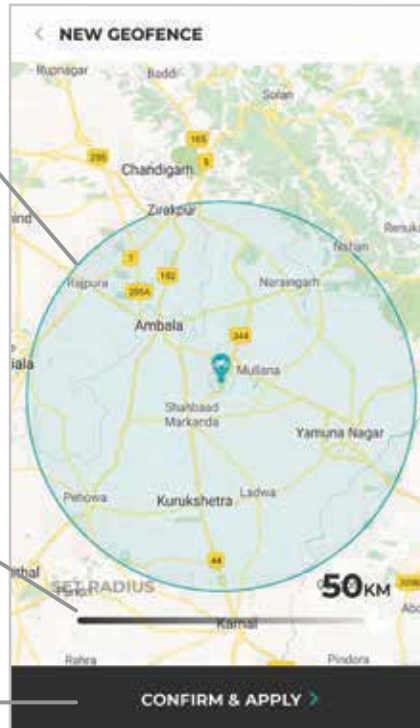

If the motorcycle goes outside the geo-fence, user will get a notification of geo-fence being breached. Motorcycle will NOT automatically stop after the breach.

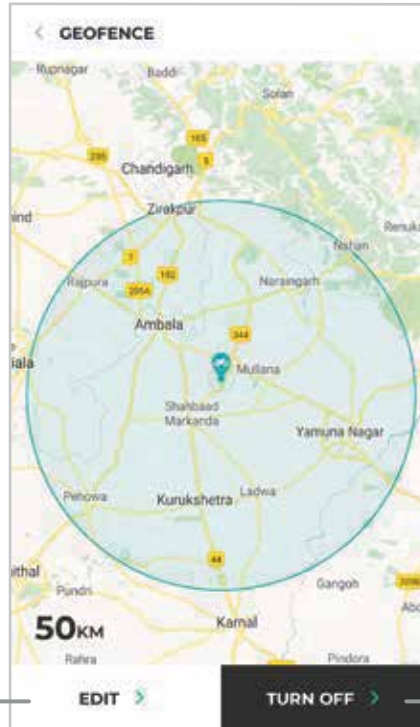

User can edit a previously applied Geofence.

User can **TURN OFF** a previously applied Geofence.

Switch Battery

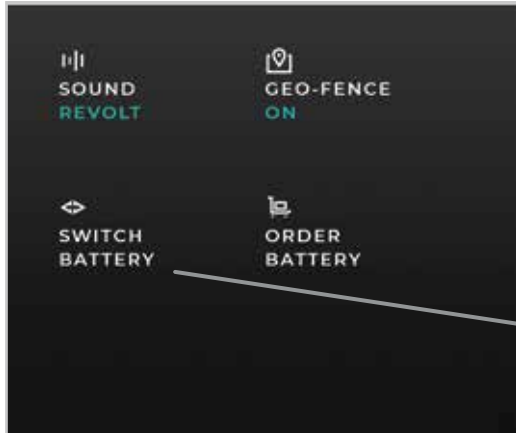

Clicking on **Switch Battery** provides the switch stations nearby with their Open/Closed status



Clicking on **Switch Battery** provides the details of the Switch Station with its location on a map and the time to reach the station.





Clicking on **Order Battery** provides an option to reach out to emergency support number for battery delivery.

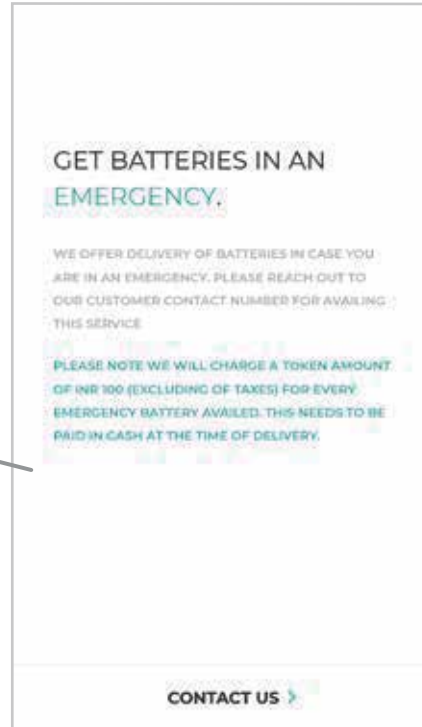



Clicking on **My Bike** from the menu allows a user to run diagnostics and view real time battery and mobile network information

Battery and Charging



Revolt Motorcycle with Battery

Batteries are the fuel of the e-motorcycle

BATTERY & CHARGER (OPERATION)

RV400 motorcycle comes with Lithium-ion (Li-ion) battery. This battery is equipped with Battery Management System (BMS) which protects the battery from damages due to short circuit, over charging, deep discharging and high temperatures.

The charger provided with the Li-ion battery is a sophisticated, special purpose electronic charger. This charger has additional protective feature which provides protection from output over voltage, output over current, short circuit, high temperature and reverse polarity.

CHARGING YOUR LI-ION BATTERY

1. Connect the charger to the battery by plugging the connector into the charger socket.
2. Plug the charger into the wall outlet, ensuring the charger is turned OFF.
3. Turn ON the charger using the switch in the wall socket.
4. The LED indications:-
 - a. The LED will change to GREEN when the battery is fully charged.
 - b. The LED will illuminate RED when the charger is plugged & the switch is in ON position.
5. When charging is complete [the indicator LED is GREEN], turn OFF the charger. Battery is now ready to use.

ADDITIONAL IMPORTANT POINTS & TIPS FOR CHARGING YOUR MOTORCYCLE:

- Batteries will take 4 to 5 hours from full discharge to full charge. Batteries are to be recharged once in every 30 days even if vehicle is not used, otherwise the warranty will be null and void.
- The Ignition switch must be in 'OFF' position when your motorcycle is being charged.
- The charger supplied with your motorcycle should only be used for the purpose of charging the battery of the motorcycle. Do not use it for any other purpose.
- The battery charger supplied with the battery is for ventilated INDOOR use only.
- Do not try to open the sealed charger. Warranty will become void for chargers with open seal.
- Keep the charger and the battery out of reach of children and pets.
- Do not use damaged components, such as power cord, charger case, plug etc. It can cause electric shock, short circuit or fire.
- Avoid leaving the battery charger ON and plugged into the battery for more than 5 hours at a time. Once the battery is fully charged, turn OFF the charger and unplug it from the pack.

CHARGER CARE TIPS:

- Ensure that charger plugged on both side is not loose and there is no sparking/heating of the mains socket.
- Although charger has auto cut off system, it is advisable to plug out the charger after 5 hours for Li-ion batteries.
- Protect charger from direct sunlight, rain or excessive dust, put it a ventilated place while charging.
- While charging, first plug-in the battery side, then the AC side. Post Charging, first unplug the AC side, then the battery side.
- Ensure ignition switch is in 'OFF' position when your motorcycle is being charged.

DRIVING YOUR MOTORCYCLE

- A. Take motorcycle off the stand
- B. Check for recommended tyre pressure for smooth running .
- C. Insert the ignition key, without turning on the throttle.
- D. Sit on the motorcycle, turn the key to “ON” position by turning clockwise.
- E. Ensure the battery is charged.
- F. Select the desired mode.
- G. It is mandatory to use a helmet for a safe ride.
- H. The motorcycle should not be overloaded by putting more load than recommended.

DO'S AND DON'TS WHILE DRIVING

- A. The power to the motor cuts off when brakes are applied to save energy. Do not hold on to the brakes when you want the motorcycle to run.
- B. Avoid going through deep pools of water. Dry your brakes by lightly applying them repeatedly.
- C. It is strongly advised that on wet, loose gravel and sandy surfaces do not apply sudden brakes and drive under controlled speed to avoid skidding
- D. Avoid abrupt acceleration and braking, as this will affect the mileage of your motorcycle.
- E. While driving, watch out for both moving and stationary vehicles on road.
- F. Do not take sharp turns while riding. Reduce the speed while turning.
- G. You are advised to switch off all light indicators and horn immediately after use.
- H. While going down a steep slope do not accelerate.
- I. Beware of pot holes while driving on road.
- J. When it is raining or on wet roads, the motorcycle can skid and the braking distance increases, so use both brakes accordingly and maintain a safe distance from other vehicles.
- K. Do not use or leave your motorcycle in waterlogged areas.
- L. Follow Traffic Rules.
- M. Although Motor is water resistant, it is advisable to avoid riding in water logged areas, especially any exposure to electric connections & components to avoid short circuit.

AFTER RIDE DO'S AND DON'TS

- After your ride, turn off ignition lock, and remove keys.
- Put the motorcycle on stand on flat ground, avoid uneven ground.
- If motorcycle needs charging, put the motorcycle for charging [as per requirement] after a gap of 30 minutes.

IMPORTANT

It is safe to be seated on your motorcycle before turning ON the power. If the power is turned ON, it could result in the motorcycle moving forward before you are ready and could cause injury. Remember that there is a auto power cut-off switch embedded into both the brake levers. When you apply the brakes, power to the motor will stop. Therefore, do not hold the brake levers when you want the motorcycle to run.

TYRE PRESSURE

An under inflated tyre can cause premature tyre failure, and will require more electrical energy to propel your motorcycle. The recommended tyre pressure for front & rear wheels are mentioned below:

TYRE	PRESSURE
Front tyre	28 psi
Rear tyre	30 psi

REVOLT

*Warranty
Policy*



Revolt Motors provides a warranty of 5 years / 75,000 KM (whichever is earlier) on motorcycle. UNLIMITED* warranty on Battery.

Warranty is valid if your motorcycle is delivered and subsequently serviced by an authorized Revolt Motors Dealer or authorized Service Centre & all the free and paid services recommended by the company are availed as per frequency and schedule mentioned in this manual.

Obligations: If any manufacturing defect(s) is(are) observed in any motorcycle within the warranty period as mentioned, Revolt Motors only obligation is to repair or replace defective parts with new parts or equivalent at no cost to the customer for the part and labor, only when Revolt Motors acknowledges that such malfunction is caused due to faulty material or workmanship during manufacturing.

The company's decision to replace or repair the affected part will be final. In the event of replacement of old parts, the company reserves the right to use parts of the same brand as the affected part or any other brand which is used by the company in the course of manufacture. All replaced parts under this warranty will become the property of the company and will be retained by the company.

*8 years or 1,50,000 kms (which ever comes first)

Warranty will be void if your motorcycle is :

- Used for carrying more than permissible load.
- Used for stunts or competitions or gaming or other type of abusive riding.
- Not serviced from authorized service stations as per schedule and frequency mentioned in the Owner Manual.
- Repaired or spare parts replaced from an unauthorized source.
- Power train components found tampered or seal found broken*.
- Fitted with accessories other than approved by Revolt Motors.
- Modified/altered for any specific use other than as a personal transport.
- Damaged due to natural or manmade calamities such as flooding, fire, falling objects, accidents etc.
- Non-functional due to natural wear and tear, ageing, misuse or negligence.
- Fitted with batteries other than those supplied by Revolt Motors.

Warranty on proprietary items of Indian Origin:

Proprietary select items like tyres are warranted by their respective Indian manufacturer and should be claimed on them directly by the customer. Revolt Motors shall not be liable in any manner to replace them though Revolt Motors dealers. However Revolt Motors will give full assistance in preferring such claims on their Indian Manufacturers.

Consumable parts which are not covered under warranty**:

Such as Front/ Rear brake pads, all bulbs, tyres, all plastic/rubber parts and all cables i.e. front/ rear brake cable etc

Revolt Motors will not be held liable for any personal injuries or damages of any type to the rider and any other person due to failure of any part of the motorcycle.

Revolt Motors will not be liable for any incident of fire to the motorcycle due to tampering of motorcycle wiring, faulty house wiring, charging in unventilated area, charging with inflammable objects in the vicinity.

NOTE: Revolt Motors reserves the right to change and withdraw any clause of Warranty policy without and prior information or notification.

*This may vary from Product to Product. ** Depends on product offer

Revolt Motors provides a UNLIMITED* warranty on Battery

*Warranty on the original battery is for 8 years or 1,50,000 KM (whichever comes first) from the date of purchase.

Warranty on replaced battery will be from date of purchase. For example, a battery set purchased on 1st of January is replaced on 1st of August, in lieu of the faulty battery, then the warranty of the new battery set will remain from 1st of January.

Design Performance parameters of the batteries

1. Revolt motorcycles fitted with a new battery gives the stated range under stated conditions .
2. Batteries are like fuel for your Revolt motorcycle and they start getting consumed with time, e.g. the range on day 1 will be the highest and day 180 will be comparatively low, and Day 300 will be lower as compared to Day 180 and so on. This is a natural phenomena of the motorcycle batteries.

Actual Performance of the Batteries

1. Range: The mileage depends on many variable factors such as Rider weight road conditions, traffic density, tyre pressure, gradeability, engine start & stop, acceleration, charge level, load, driving style and the condition of motorcycle and battery maintenance. The mileage will reduce as battery is consumed. The mileage will also reduce as battery grows old which is a normal decay phenomena.
2. The mileage and the condition of your motorcycle batteries can reduce more if any of the steps mentioned in Battery Health Tips card given to you at the time of delivery of motorcycle (also reproduced in the manual) are not carried out properly.

BATTERY CARE AND PRECAUTION



1. Heat kills the battery. Avoid charging immediately after long ride. Try charging it in the night.
2. Battery loses charge even when not in use. Charge Li-ion battery once in 30 days, even if not riding.
3. Batteries are sealed. Do not attempt to open them.
4. When charging the battery outside the motorcycle, they must be kept in ventilated area away from inflammable material and out of reach of children & pets.
5. Batteries must be kept as cool as possible to ensure long life & good performance. Batteries become very hot & starts to degrade if motorcycle is overloaded & driven for a long distance, is charged under sunlight, is charged immediately after riding or the charger is kept 'ON' for a long period of time, even after the battery is fully charged. The battery life of your vehicle can be substantially extended by following simple tips mentioned in the Battery Health Tips card & the owner manual handed over to you at the time of purchase of this motorcycle.

TROUBLESHOOTING



All the motorcycles are carefully inspected before they are delivered. But even after the motorcycle are inspected, some technical issues may occur.



***Service
Schedule***

Free/ Paid Service and Periodical Maintenance Schedule for Lithium-ion Battery

Particulars	Free Services*					
	*Only periodic maintenance charges are free.					
	1st FS 30 Days/ 1,000 KM*	2nd FS 210 Days/ 10,000 KM*	3rd FS 420 Days/ 20,000 KM*	4th FS 630 Days/ 30,000 KM*	5th FS 840 Days/ 40,000 KM*	6th PS 1,080 Days / 50,000 KM
* Validity of services are as per periodic maintenance schedule given Days/KM whichever is earlier.						
Mention Date						
Mention Job Card No.						
Both Brakes C&A	C & A	C & A	C & A	C & A	C & A	C & A
All Control Cables	I	I	I	I	I	I
Operations of all locks	I & L	I & L	I & L	I & L	I & L	I & L
Operations of all switches	I	I	I	I	I	I
Operations of Horn	I	I	I	I	I	I
Working of all lights	I	I	I	I	I	I
Wiring Check for intact insulation	I	I	I	I	I	I
Control Cable Free play & Functions	I & A	I & A	I & A	I & A	I & A	I & A
Road Test For:-						
1. Rear & Front Brake Operations	I	I	I	I	I	I
	* Brake Pads need to be checked & adjusted at every 5,000 KM/ replaced at every 10,000 KM.					
2. Throttle Functions	I	I	I	I	I	I
3. Movement of Handle bar	I	I	I	I	I	I
4. Motor Operation	I	I	I	I	I	I
5. Movement of Wheel & their Free Movement	I	I	I	I	I	I
6. Front Fork Play	I	I	I	I	L/T	L/T
7. Front & Rear Suspension Functions	I	I	I	I	I	I
MCB Connections	I	I	I	I	I	I
Battery Terminal Connections	I & C	I & C	I & C	I & C	I & C	I & C
Tyre Pressure I & A	I & A	I & A	I & A	I & A	I & A	I & A
Tyre Wear	I	I	I	I	I	I
Belt tension	I & A	I & A	I & A	I & A	I & A	I & A
	* Belt needs to be inspected at every 3,000 KM/ replaced at every 30,000 KM					
Electrical Couplers and Joints	I & C	I & C	I & C	I & C	I & C	I & C
Front & Rear Wheel Bearing	I	I	I&L	I&L	I&L	I&L
* Under Free service Labour Charges will be FREE. parts, incidentals & others are chargeable. ** Battery rotation and CDC are periodical maintenance hence not covered in free service						
A- Adjust C- Clean R- replace, L- Lubricate, CDC- Charge, Discharge & Charge TR- Tyre Rotate I- Inspect, Correct & Replace if required T- Tighten to specified torque						

Free/Paid Service and Periodical Maintenance Schedule for Li-ion Battery

Particulars	Free Services*				Free Services*			
	*Only periodic maintenance charger are free.							
	1st FS 60 days/ 1,000 KM*	2nd FS 200 days/ 5,000 KM*	3rd FS 340 days/ 10,000*	4th FS 480 days/ 17,500KM*	5th PS 620 days / 25,000KM*	6th PS 760 days/ 32,500KM*	7th PS 900 days / 40,000KM*	8th PS 1080 days / 50,000KM*
* Validity of services are as per periodic maintenance schedule given Days/KM whichever is earlier.								
Mention Date								
Mention Job Card No.								
Road Test For:-								
1. Rear & Front Brake Operations								
* Brake Pads need to replace at every 10,000KM.								
2. Throttle Functions								
3.Movement of Handle bar								
4.Motor Operation								
5.Movement of Wheel & their Free Movement								
6.Front Fork Play				L/T	L/T		L/T	
7.Front & Rear Suspension Functions								
* Under Free service Labour Charges will be FREE. parts, incidentals & others are chargeable. ** Battery rotation and CDC are periodical maintenance hence not covered in free service								
A- Adjust C- Clean R- replace , L- Lubricate, CDC- Charge, Discharge & Charge TR- Tyre Rotate I- Inspect, Correct & Replace if required T- Tighten to specified torque								

Service Record



Service	Duration	Job Card No.	Service Date	KM Reading	Dealer Signature & Stamp
1st	1,000 KM/ 30 Days * Whichever is earlier				
2nd	10,000 KM/ 210 Days * Whichever is earlier				
3rd	20,000 KM/ 420 Days * Whichever is earlier				
4th	30,000 KM/ 630 Days * Whichever is earlier				
5th	40,000 KM/ 840 Days * Whichever is earlier				
6th	50,000 KM/ 1,080 Days * Whichever is earlier				



REVOLT